

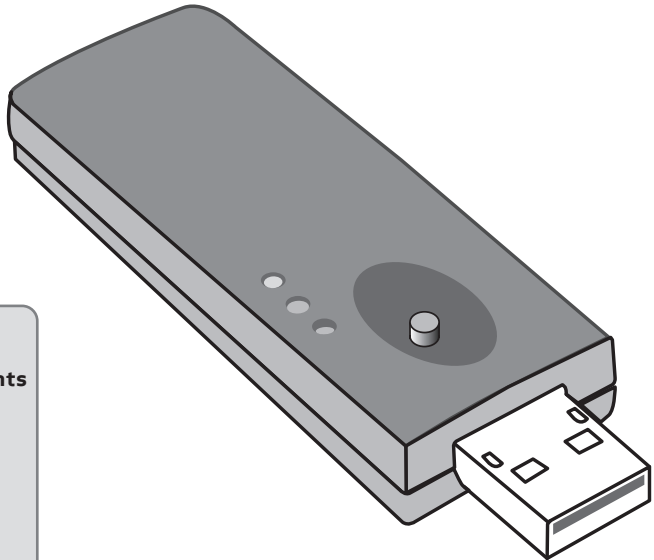

# SimplyWorks®

## INSTRUCTIONS

### RECEIVE:2



#### Pack Contents

Carefully check the contents of the box, which are:

**RECEIVE:2**

**This manual**

### Product Description

SimplyWorks® is the world's first fully integrated wireless system specifically for users with motor skills difficulties.

**RECEIVE:2** forms the hub of the system when used for computer access and works with up to six SimplyWorks® transmitters of any kind. It supports **TRACKBALL**, **JOYSTICK**, **SWITCH 125**, **SWITCH 75**, **SEND**, **SEND-6**, **KEYBOARD** and **SMOOTH TALKER** functions all via a single USB connection to the host computer and without dedicated driver software.

SimplyWorks® allows you the freedom to create wire-free, single or multi-user learning environments, reducing set up time and allowing you to concentrate on the learning tasks themselves.

**RECEIVE:2** is simple to operate but to ensure you get the most from your purchase, please take time to read this instruction booklet.

# Features

---

- State of the art multi-channel wireless receiver with a range in excess of 10m, making it ideal for classroom environments.
- Supports up to six transmitters simultaneously.
- No restriction on the mix of transmitters.
- Caps Lock and Drag Lock LEDs.
- USB connectivity.
- No additional drivers required.
- PC and Mac compatibility.
- Compact design.

## Compatibility

---

**RECEIVE:2** is compatible with all PC and Mac platforms that are fitted with a USB socket and makes use of advanced features that are not available on the PS/2 style connectors; so the unit cannot be used in the PS/2 socket of your computer even via an adaptor plug.

**RECEIVE:2** is also compatible with some tablet computers via a cable adaptor. Most Android based tablets may be used, but not Apple iPad, iPod or iPhone.

## Installation

---

Ensure your computer is fully turned on and booted up. Locate a spare USB socket on your computer and plug in your **RECEIVE:2**. The unit will automatically be recognised by the computer and the relevant drivers loaded. The Pair LED will light for 5 seconds. Because **RECEIVE:2** supports many different functions, the computer will load several drivers, so the process may take up to a minute.

Once completed, the operating system will usually inform you the process has finished.

To optimise the range of the wireless link, it is recommended that you do not place the unit behind your computer, close to large metal objects or sources of interference such as wireless network hubs, cellular telephones etc.

## Pairing

---

Before **RECEIVE:2** can be used it must be paired with the SimplyWorks® transmitters that you require it to work with. Irrespective of the specific product, the procedure is the same:

- 1 Place the transmitter unit it is to be paired with close to your **RECEIVE:2**.
- 2 Briefly press the Pair button (A) on **RECEIVE:2**. The pair LED (B) will begin to flash slowly.
- 3 Within 10 seconds, press the Pair button on the transmitter.
- 4 The Pair LED on **RECEIVE:2** will continue to flash for a short time while it negotiates with the transmitter. Once complete, the Pair LED will light steadily for 5 seconds

to indicate success. The transmitter is then ready to use. Whenever data is successfully received from a transmitter device, the Pair LED will flash briefly to give visual indication that the radio link is operational.

- 5 If the Pair LED stops flashing after 30 seconds and does not light steadily, repeat the process from (2). If it is still not successful, please refer to the Troubleshooting section.

Pairing information for all six channels is retained in **RECEIVE:2**'s internal memory even after powering down your computer.

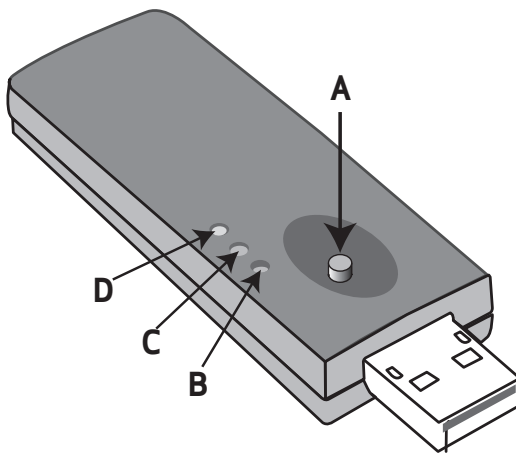

---

## Multiple Transmitters on one RECEIVE:2

Your RECEIVE:2 can support up to six transmitter units simultaneously. Pairing the second and subsequent transmitters is just like pairing the first.

If you should attempt to pair a seventh transmitter unit, the transmitter unit that has been used least recently will be replaced by the new one. The other five transmitters are unaffected. This way, transmitters that are no

longer being used with this RECEIVE:2 are the first to be replaced.

If at any stage you would like to start the pairing procedure over again, first press and hold the Pair button [A] for around 3 seconds. The Pair LED [B] will flash quickly and the pairing information for all 6 channels will be erased, allowing you to start over.

---

## Caps Lock and Drag Lock LEDs

An LED is provided on your RECEIVE:2 for both Drag Lock [C] (mouse latching left click) and Caps Lock [D] (keyboard capitals). This is useful where multiple users are each using mouse and keyboard functions.

---

## Learning Scenarios

The SimplyWorks® concept opens up a wealth of new learning scenarios that you can devise as your experience grows. Because the six channels may be occupied by any mix of SimplyWorks® transmitters, the possibilities are virtually endless.

For example, you may choose to have a single-user scenario where a TRACKBALL, keyboard and a number of switches are paired

with a RECEIVE:2. Equally, both a TRACKBALL and a JOYSTICK may be used simultaneously to allow users with different abilities to access the same computer.

Alternatively, a multi-user scenario may comprise six keyboards or six TRACKBALLs, for example, allowing several workgroups to access an interactive whiteboard.

---

## Maintenance

Your RECEIVE:2 has no user serviceable parts. If repair is necessary the unit should be returned to Pretorian Technologies or an authorised distributor.

# Troubleshooting

If your **RECEIVE:2** does not operate correctly, please use the following guide to determine the cause. If, after following this guide, your unit still does not operate, please contact your supplier before returning it.

Symptom	Possible Cause / Remedy
Transmitter unit not functioning	<ul style="list-style-type: none"><li>• Units are not Paired - follow procedure in Pairing section.</li><li>• Batteries in transmitter unit flat - replace.</li></ul>
Transmitter works erratically or intermittently.	<ul style="list-style-type: none"><li>• Batteries in transmitter unit flat - replace.</li><li>• Out of range - move transmitter unit closer to <b>RECEIVE:2</b>.</li><li>• Interference - place both transmitter and <b>RECEIVE:2</b> unit away from sources of interference. Also try re-booting from cold to change radio channels.</li></ul>
Units will not Pair - LED is extinguished after 30 seconds	<ul style="list-style-type: none"><li>• Batteries in transmitter unit flat - replace.</li><li>• Ensure transmitter unit is close to <b>RECEIVE:2</b> (e.g. 1 metre/ 1 yard) while pairing.</li></ul>

## Warranty

Your **RECEIVE:2** is warranted against defects in manufacture or component failure. The unit is designed for domestic and educational applications. Use outside these areas will invalidate the warranty. Unauthorised repair or modification, mechanical abuse, immersion in any liquid or connection to incompatible equipment will also invalidate the warranty.

**Pretorian**  
TECHNOLOGIES LTD.

Unit 37 Corringham Road Industrial Estate  
Gainsborough Lincolnshire DN21 1QB United Kingdom

**Tel** +44 (0) 1427 678990 **Fax** +44 (0) 1427 678992

SimplyWorks<sup>®</sup> is a registered trademark of Pretorian Technologies Ltd.